

## NOTICE TO MARINERS M35 of 2018

### THAMES BARRIER CONTROL ZONE THAMES BARRIER TEMPORARY NAVIGATION LIGHTS

Mariners are advised that the works **formerly promulgated in Notice to Mariners M13 of 2018** will continue on the Thames Barrier to upgrade the existing navigation lights on each of the piers. These works are expected to last approximately three months.

In order to facilitate continued safe navigation through the Thames Barrier a temporary red cross will be utilised to indicate a span that is currently closed to navigation from one or both directions.

This temporary lighting arrangement will be 1m x 1m in size and consist of five red lights mounted onto a rigid red 'X' as illustrated below:

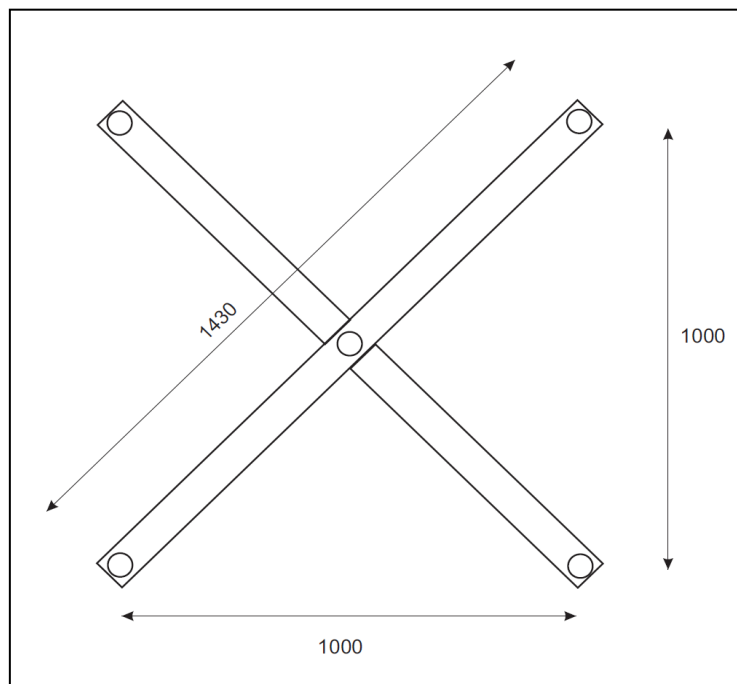

For the latest information contact London VTS on VHF Channel 14 or by telephone on 0208 855 0315.

**2 May 2018**

Port of London Authority  
London River House, Royal Pier Road,  
Gravesend, Kent DA12 2BG

**BOB BAKER**  
CHIEF HARBOUR MASTER



EXPIRY DATE: 31<sup>st</sup> July 2018  
TO RECEIVE FUTURE NOTICES TO MARINERS BY **E-MAIL**,  
PLEASE REGISTER VIA OUR WEBSITE [www.pla.co.uk](http://www.pla.co.uk)  
**Telephone calls, VHF radio traffic, CCTV and radar traffic images may  
be recorded in the VTS Centres at Gravesend and Woolwich**

